



SMILEY[®]
MONROE

CONVEYOR BELT SERIES

CHEVRON PROFILE DESIGNS

CONVEYOR BELT SERIES

CHEVRON PROFILE DESIGNS

Smiley Monroe's Chevron conveyor belts are designed for space-saving, steep inclined conveying, where they deliver increased capacity when carrying bulk materials - such as **crushed rock, construction & demolition waste and sand & gravel.**

At our production centre in **Northern Ireland** we hold large stocks of Chevron belts manufactured to **DIN 22102 Standard** - rigorously tested in our fully equipped Belt Testing Labs - which combine excellent cut, impact and wear resistance with great troughability.

This brochure is designed to provide you with our most popular patterns and cleat heights available from stock.

Our Chevron multi-ply belts are also available in **ToughFlex[®], Fabric Breaker** and **Ripstop** for your toughest applications and we can supply specialised **oil, heat, fire and frost resistant belts** for applications demanding extreme operating conditions ranging from **-60°C to +600°C** (standard operating range -40°C to +60°C).

In addition to our popular **15mm** and **25mm** high **cleated chevron belts, with V-splices as standard**, we are accomplished in producing a wide range of **patterns and cleats** and our

setup enables us to create **cleated, side rail, sidewall, T-cleat** and **overband magnet belts**, using hot vulcanising, to suit customer requirements.

With customisation at our core and your Aftermarket in mind, we can even brand belts with your company logo and supply them as **Prepared belts (ready to splice), Cut Length belts (ready to prepare)** and as **ZIP CLIP[®] Replacement belts (mechanically fastened).**

Get in touch with our team to help select the right belt for your application.

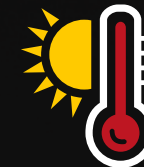

BELT OPERATING TEMPERATURES

Standard range
-40°C to +60°C
(-40°F to +140°F)

Extreme conditions
(specialised belts)
-60°C to +600°C
(-76°F to +1,112°F)

V6

**SMILEY[®]
MONROE**

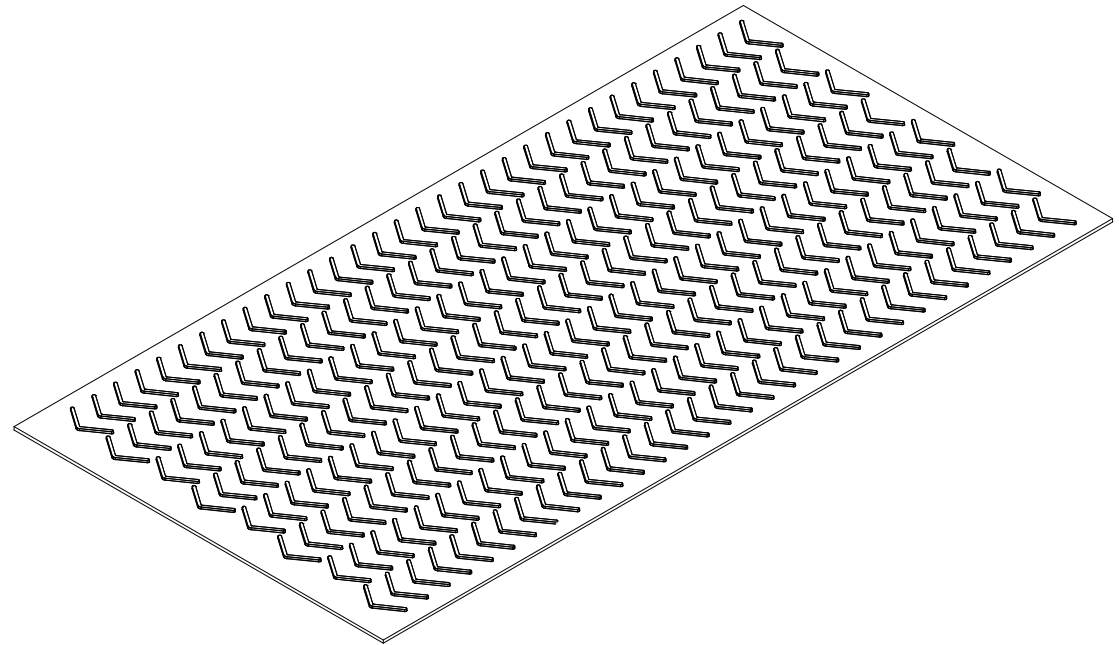
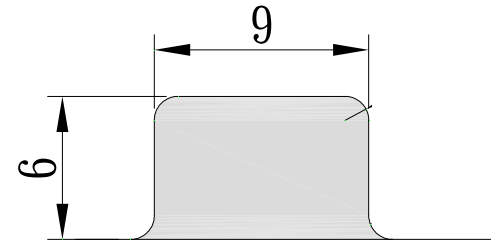
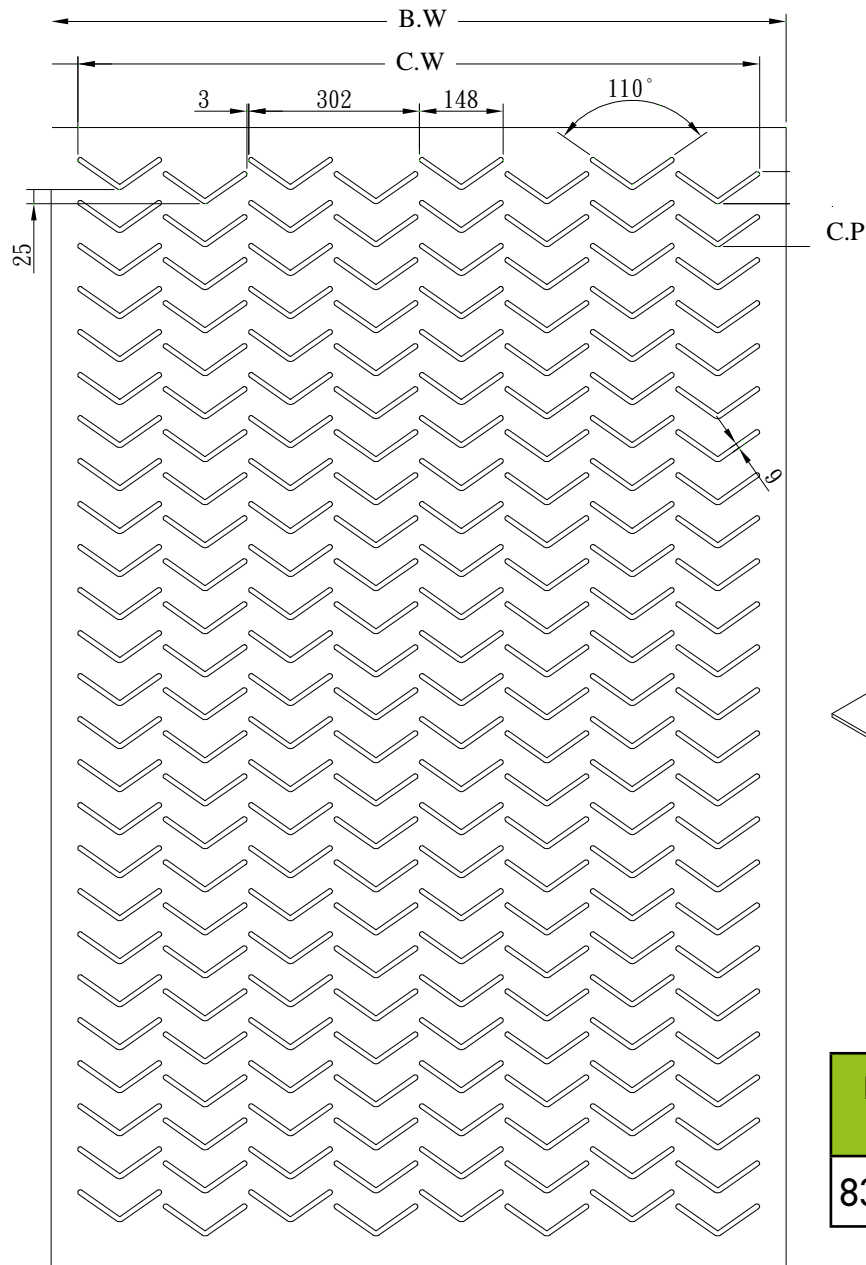

Belt Width (B.W) (mm)	Cleat Width (C.W) (mm)	Cleat Pitch (C.P) (mm)	Cleat Height (C.H) (mm)
830,1200 & 1500	830,1200 & 1500	75	6

E6P710

SMILEY[®]
MONROE

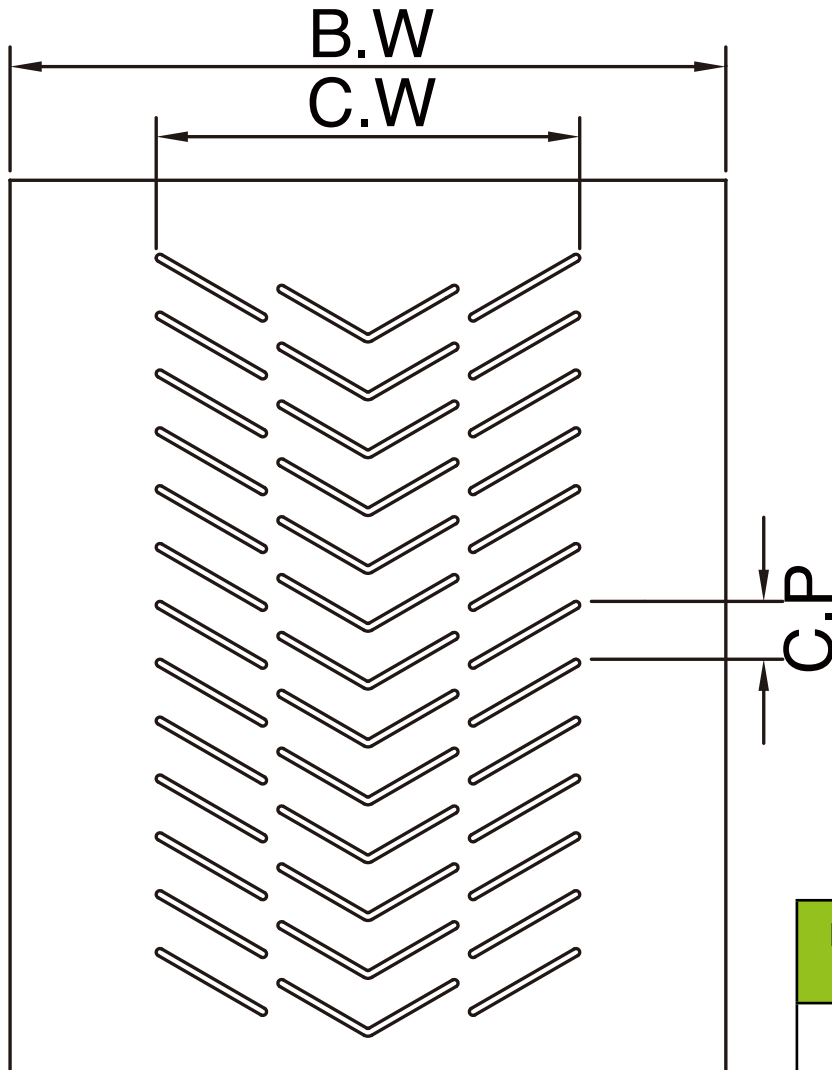

Belt Width (B.W) (mm)	Cleat Width (C.W) (mm)	Cleat Pitch (C.P) (mm)	Cleat Height (C.H) (mm)
1200	710	97	6

C12V250

**SMILEY
MONROE**

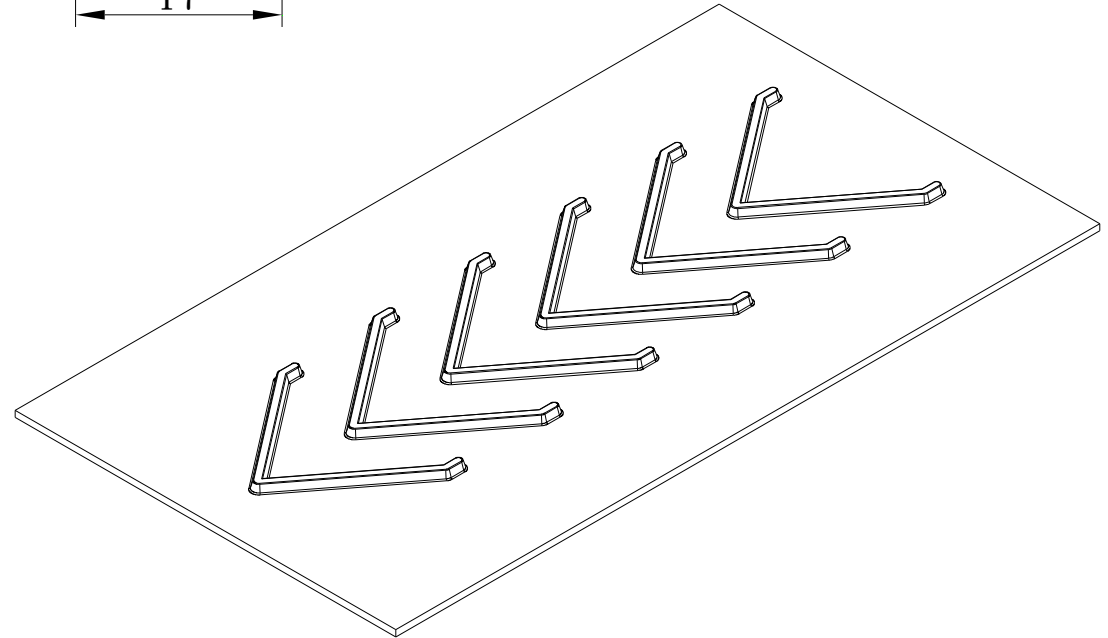
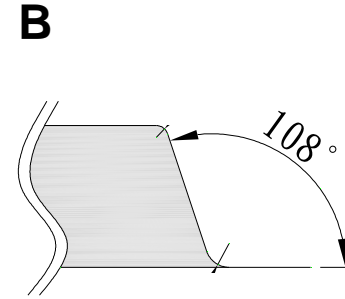
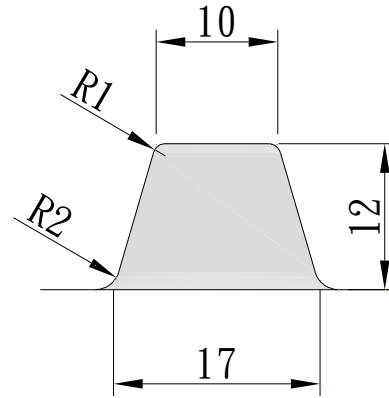
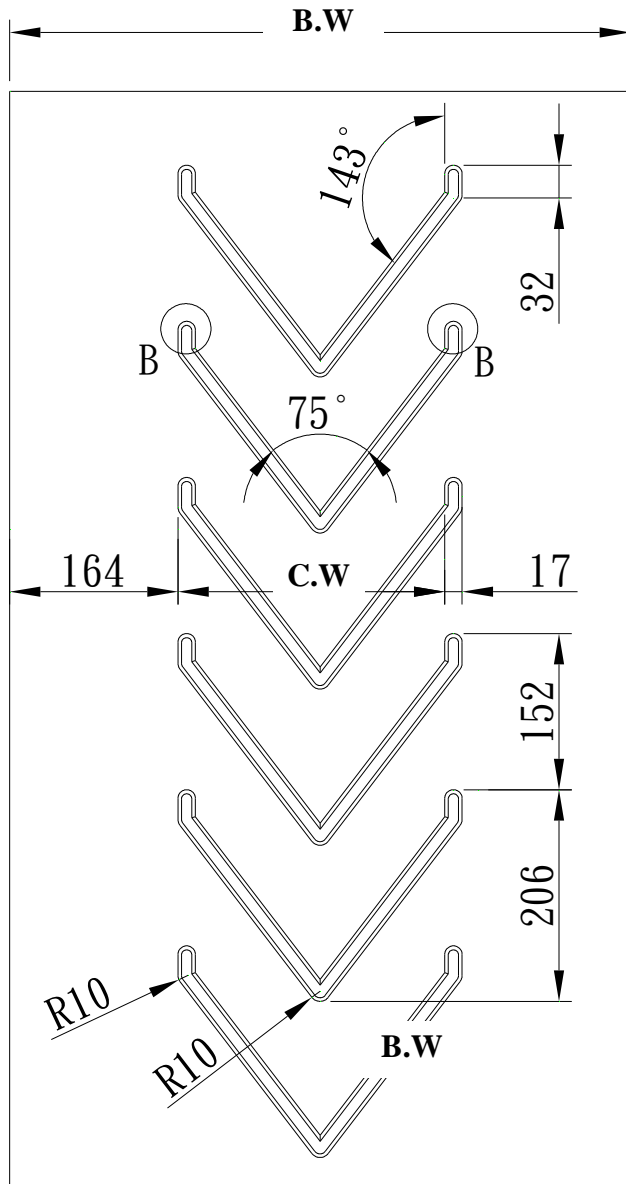

Belt Width (B.W) (mm)	Cleat Width (C.W) (mm)	Cleat Pitch (C.P) (mm)	Cleat Height (C.H) (mm)
400 & 500	275	150	12

C15P385

SMILEY[®]
MONROE

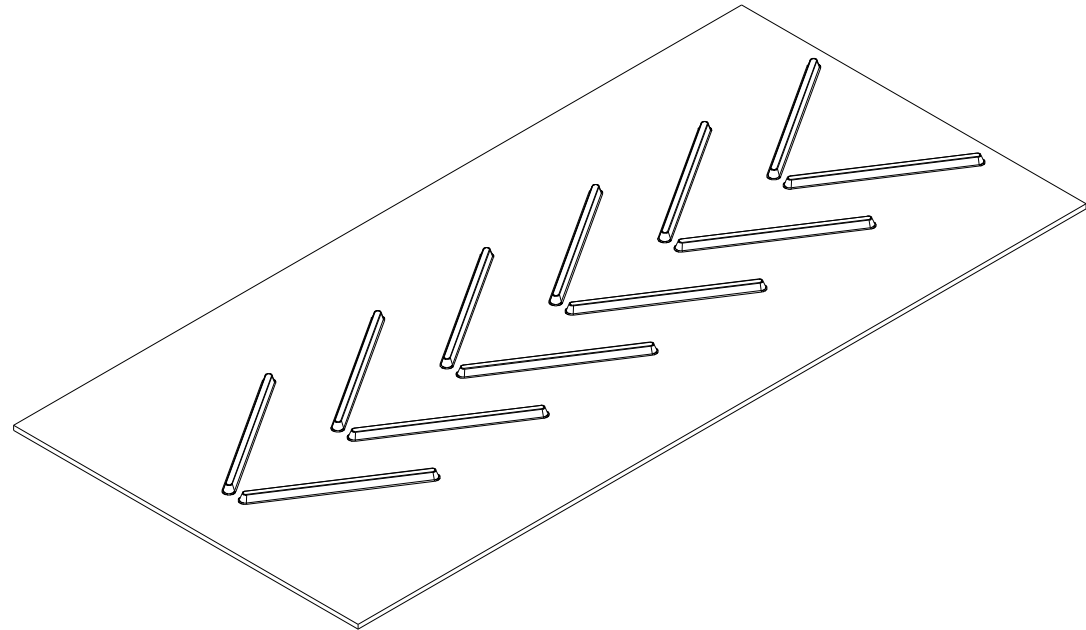
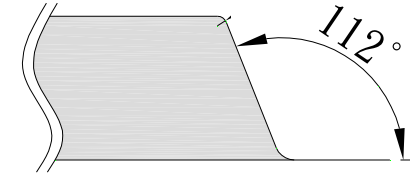
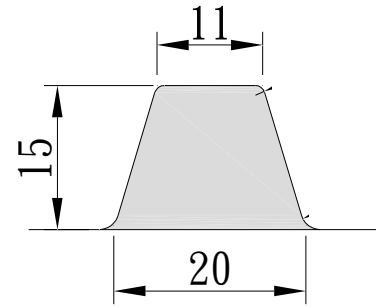
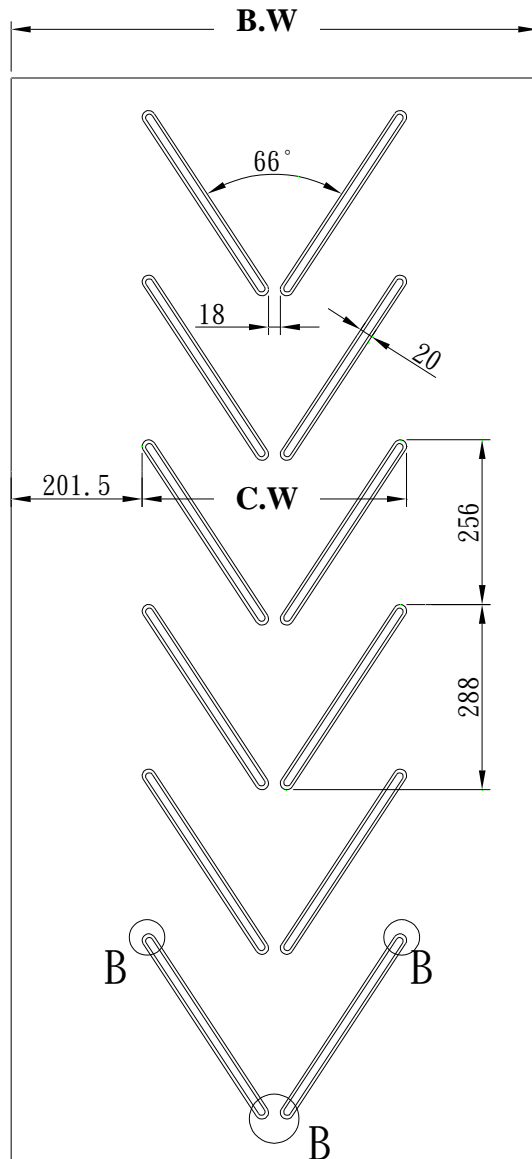

Belt Width (B.W) (mm)	Cleat Width (C.W) (mm)	Cleat Pitch (C.P) (mm)	Cleat Height (C.H) (mm)
450 - 800	400	250	15

C15P600

SMILEY[®]
MONROE

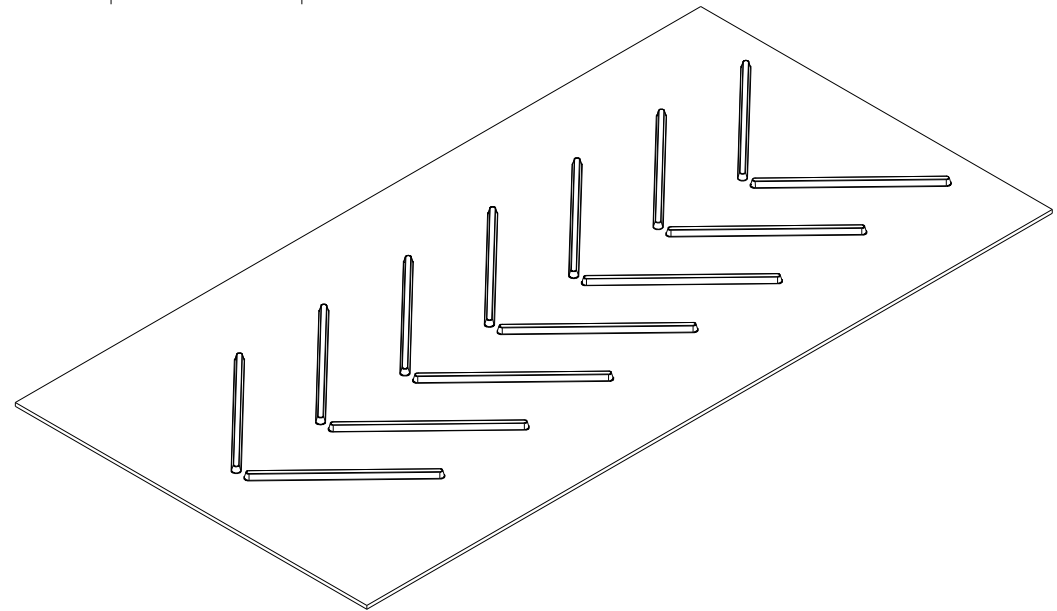
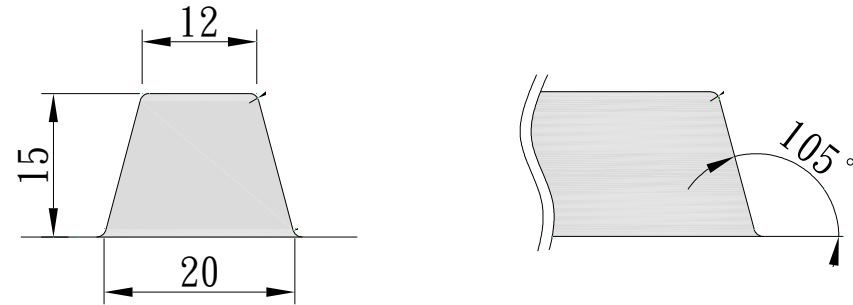
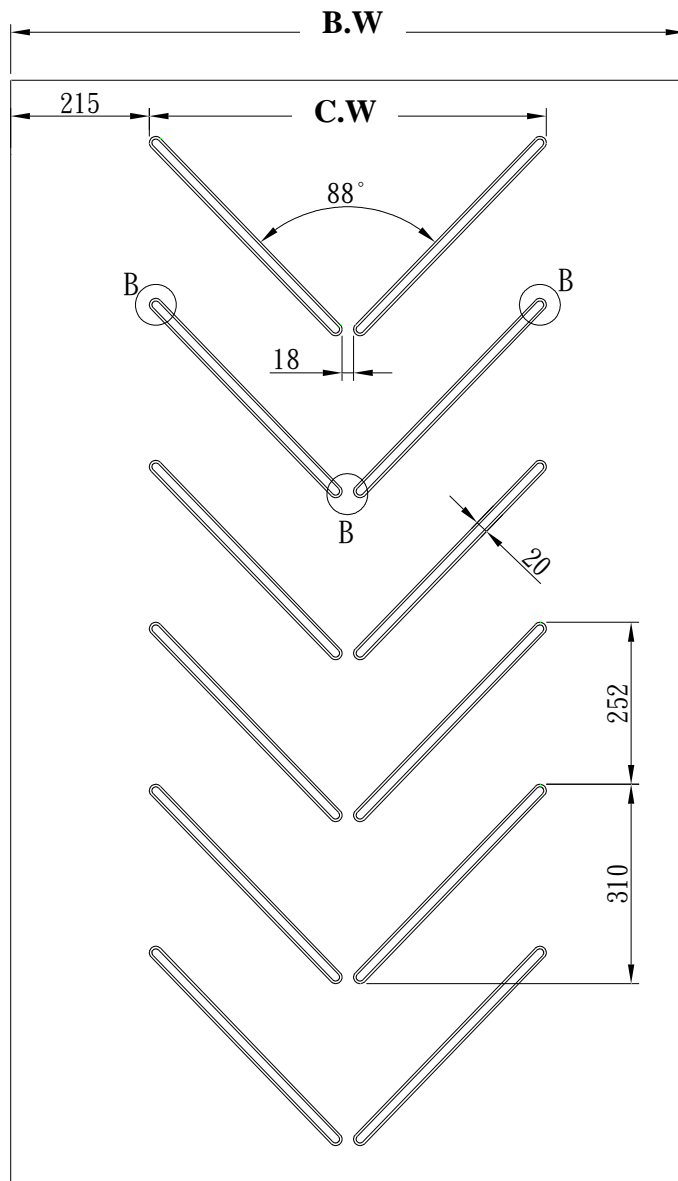

Belt Width (B.W) (mm)	Cleat Width (C.W) (mm)	Cleat Pitch (C.P) (mm)	Cleat Height (C.H) (mm)
900, 1000 & 1050	610	250	15

C15P750

SMILEY[®]
MONROE

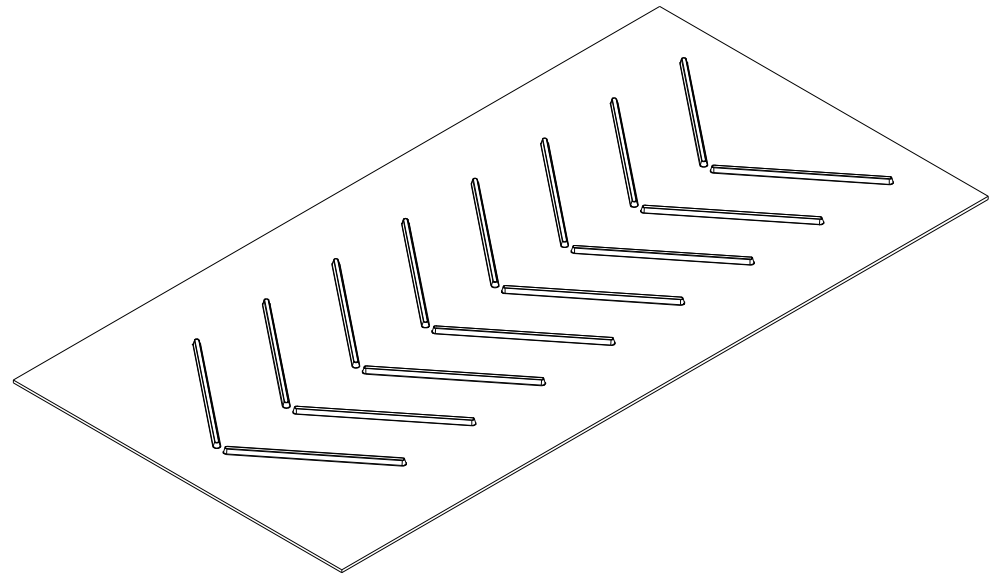
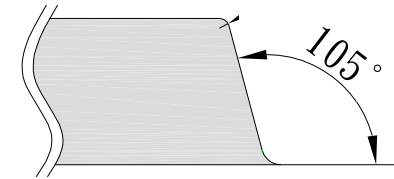
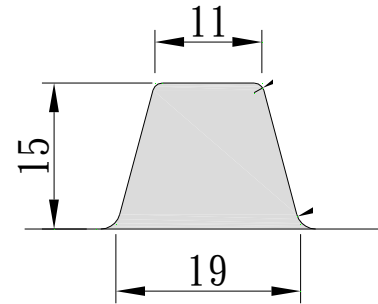
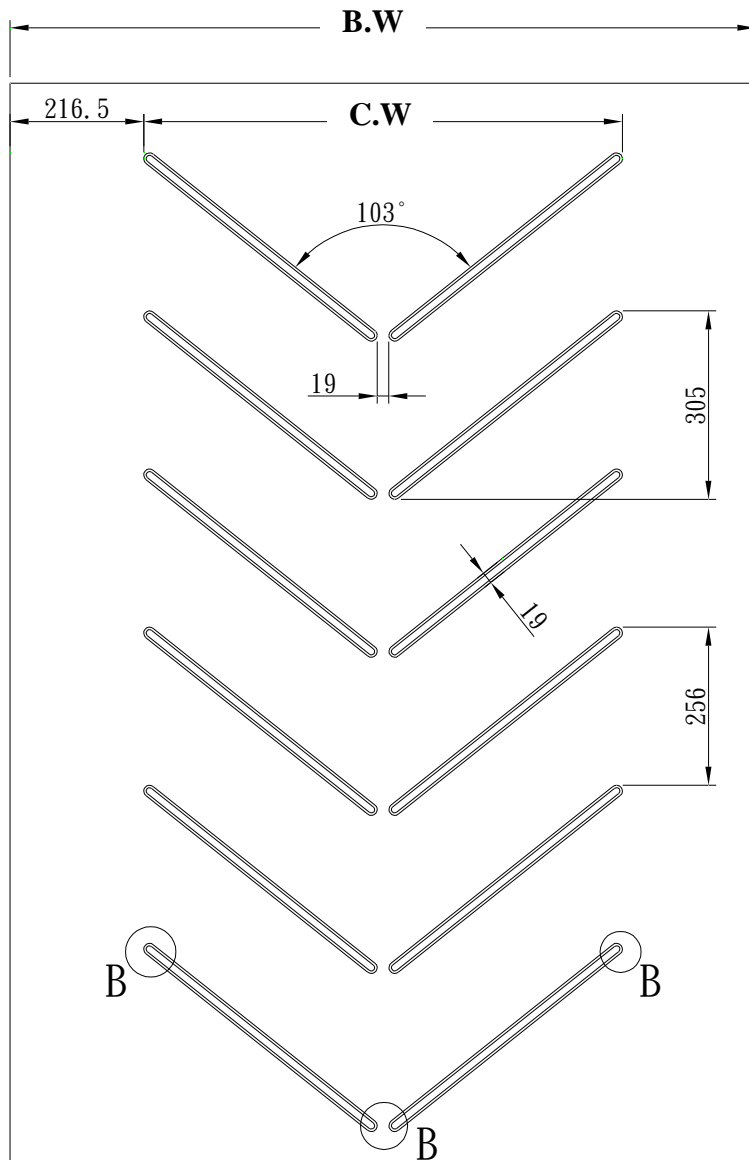

Belt Width (B.W) (mm)	Cleat Width (C.W) (mm)	Cleat Pitch (C.P) (mm)	Cleat Height (C.H) (mm)
1050	770	250	15

C15V330

SMILEY[®]
MONROE

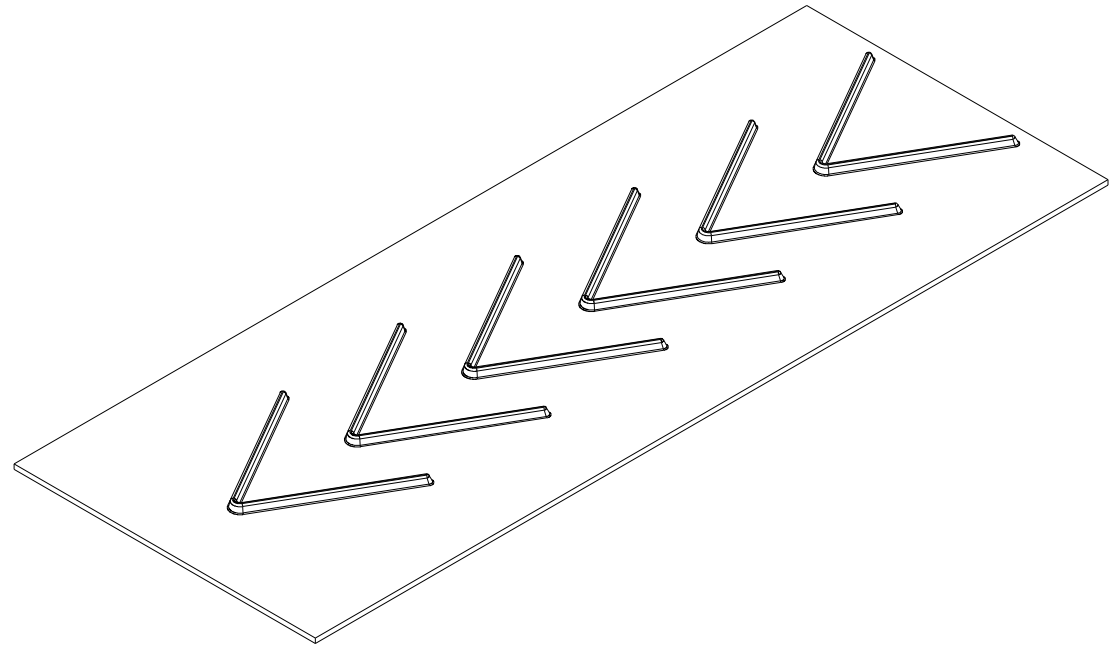
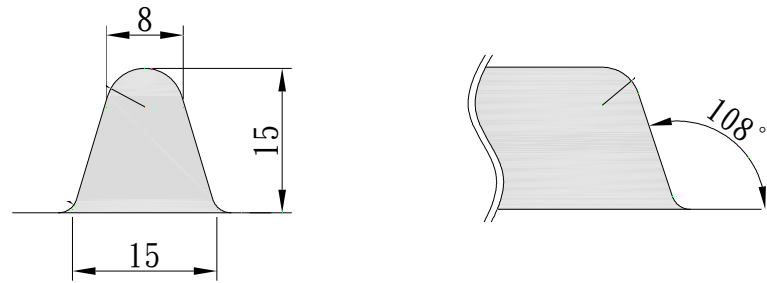
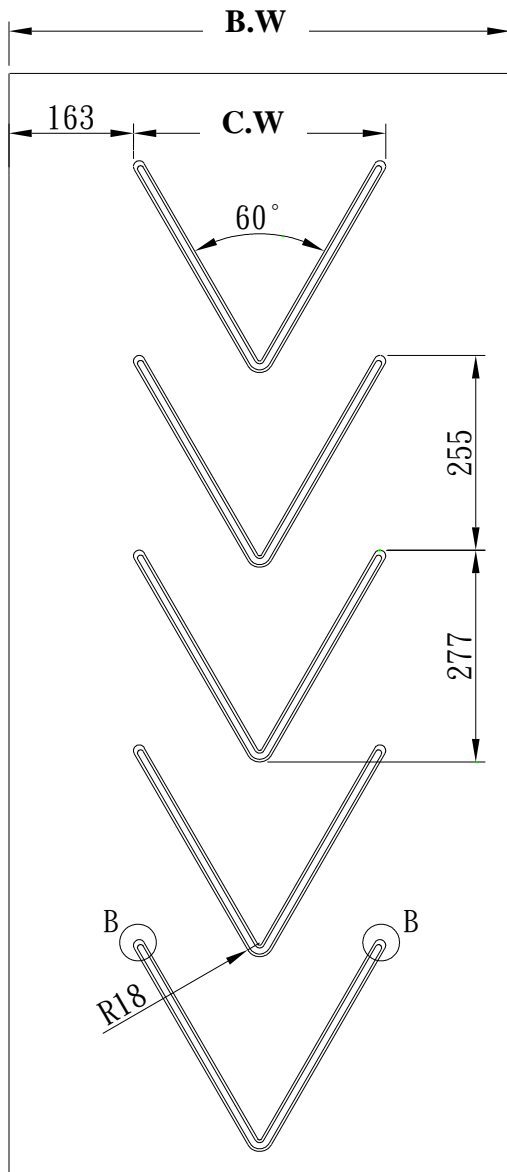

Belt Width (B.W) (mm)	Cleat Width (C.W) (mm)	Cleat Pitch (C.P) (mm)	Cleat Height (C.H) (mm)
400	330	250	15

C15V450

SMILEY[®]
MONROE

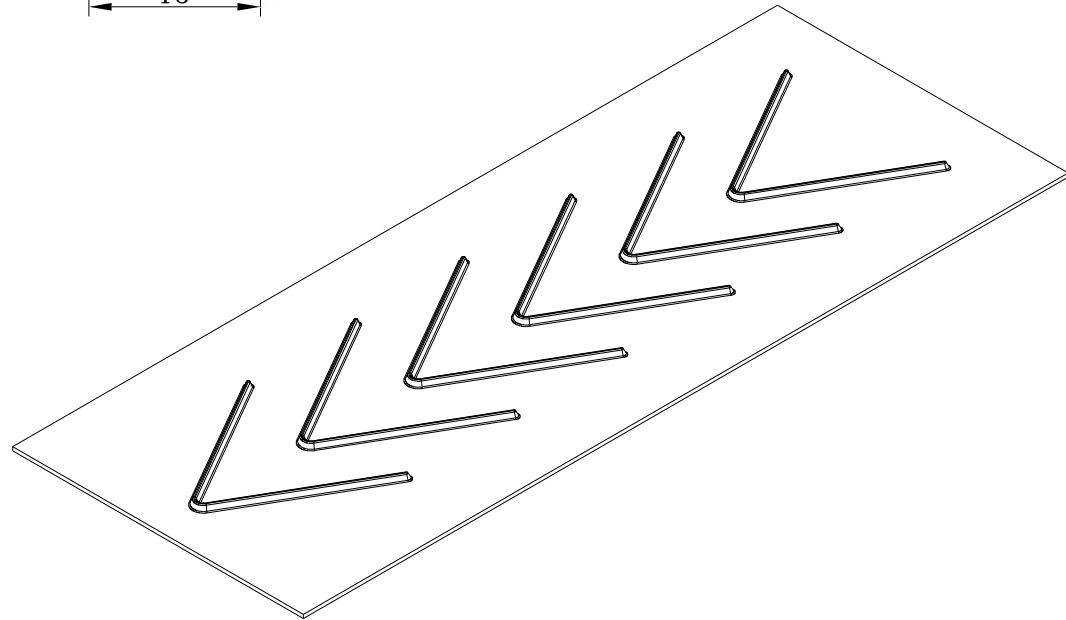
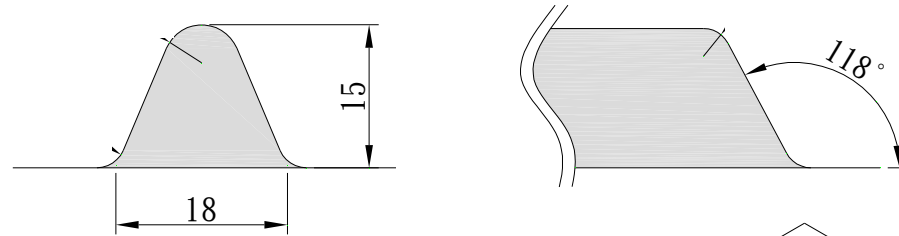
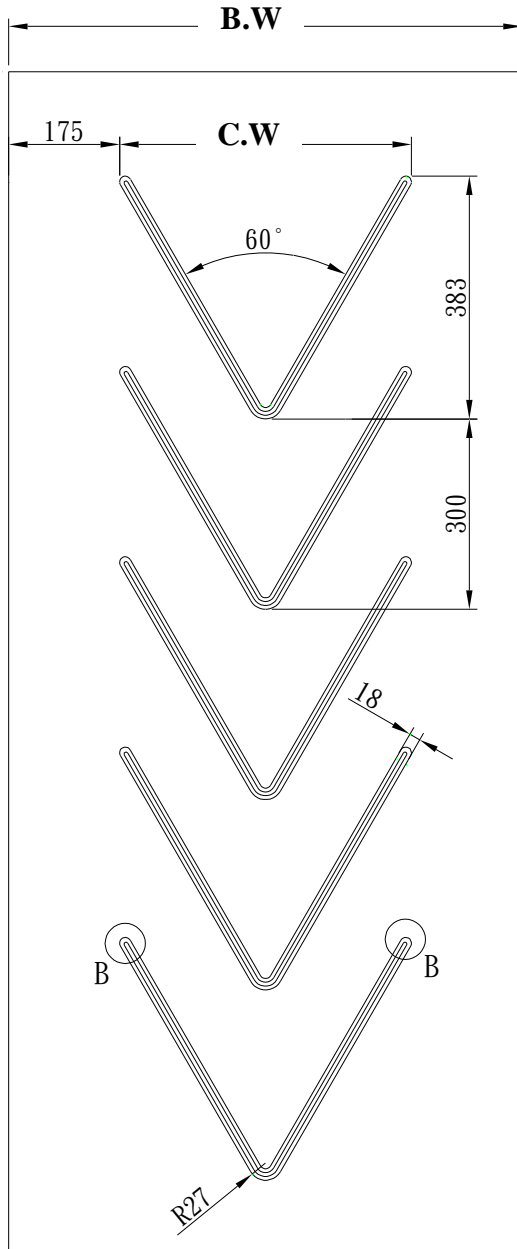

Belt Width (B.W) (mm)	Cleat Width (C.W) (mm)	Cleat Pitch (C.P) (mm)	Cleat Height (C.H) (mm)
900	450	300	15

C25P450

SMILEY[®]
MONROE

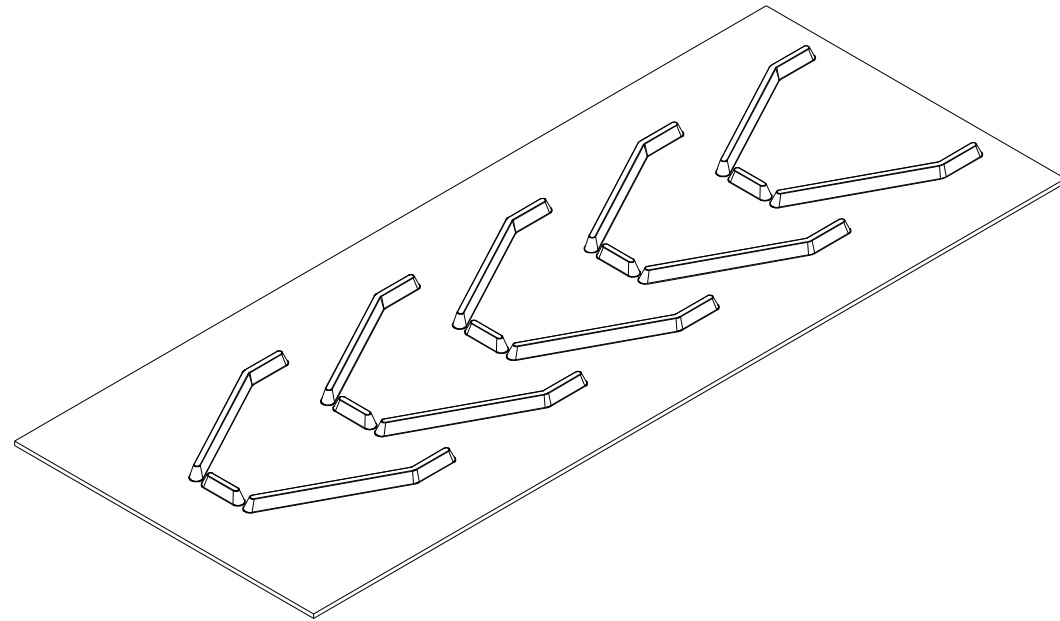
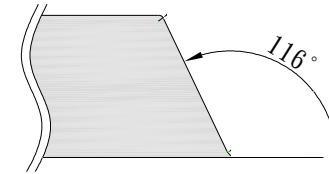
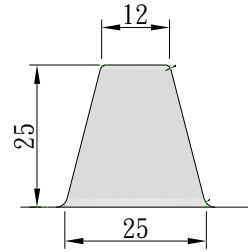
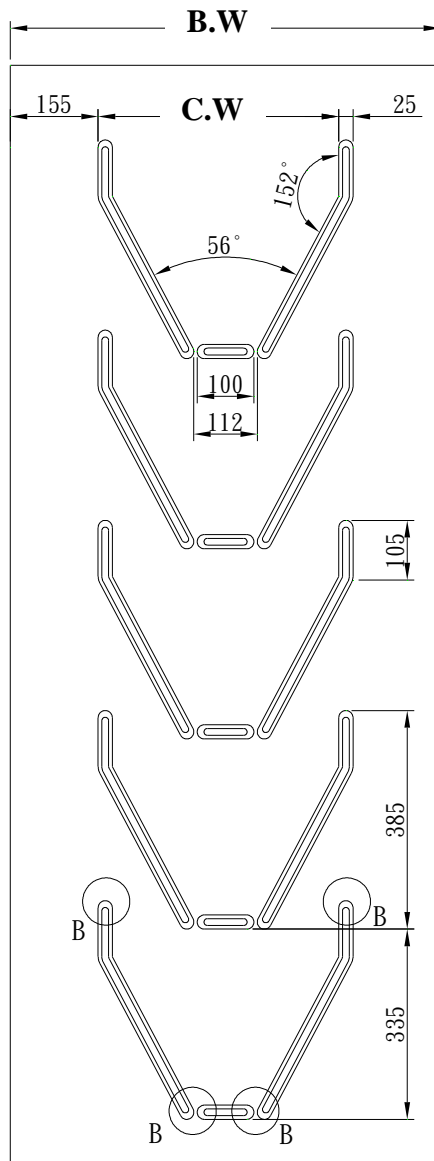

Belt Width (B.W) (mm)	Cleat Width (C.W) (mm)	Cleat Pitch (C.P) (mm)	Cleat Height (C.H) (mm)
650	450	335	25

C25P550

SMILEY[®]
MONROE

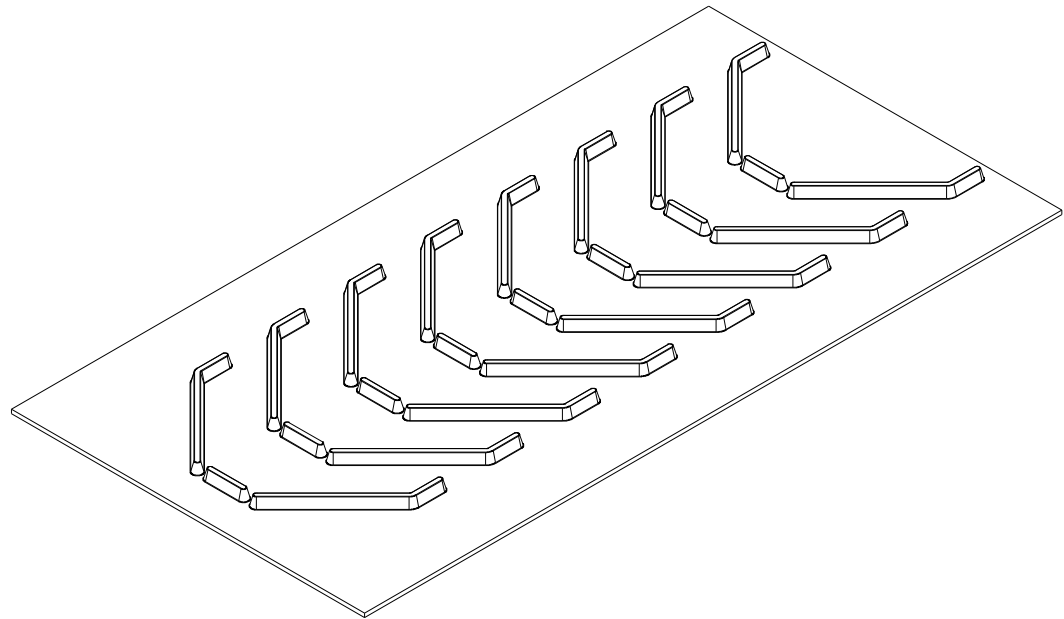
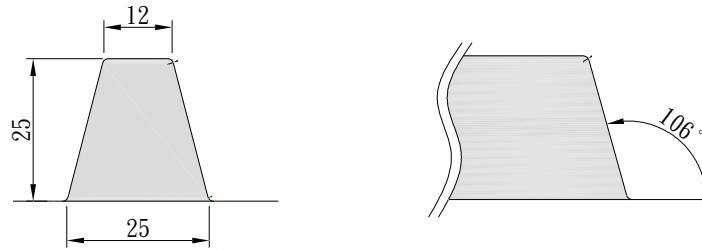
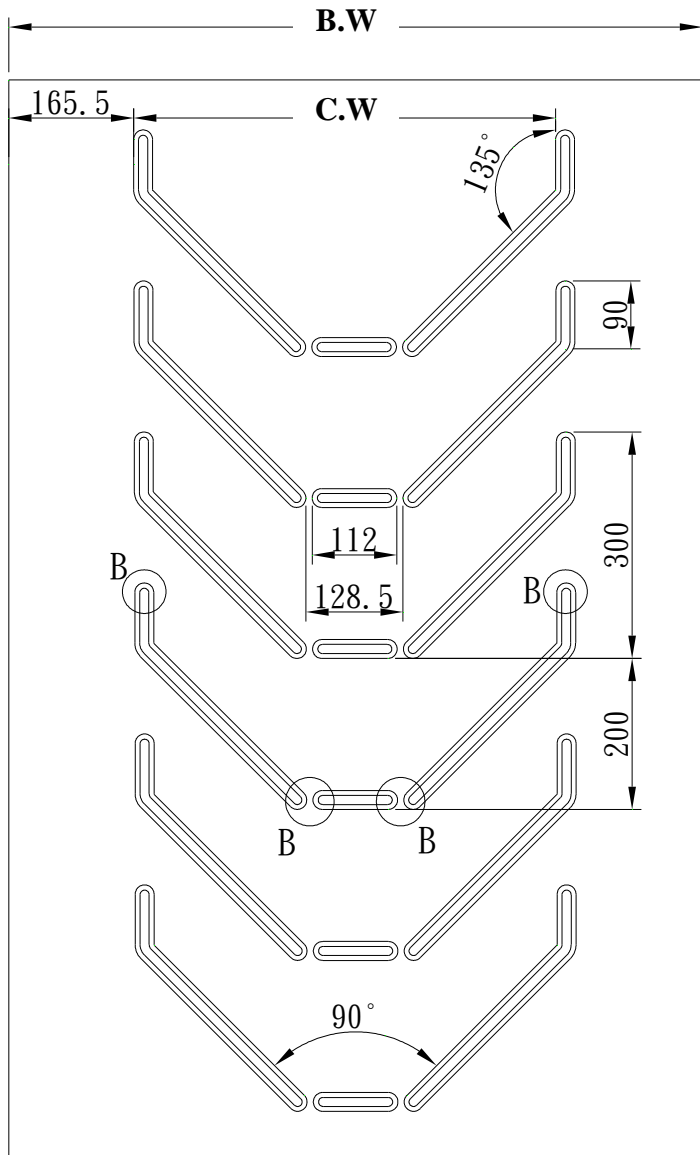

Belt Width (B.W) (mm)	Cleat Width (C.W) (mm)	Cleat Pitch (C.P) (mm)	Cleat Height (C.H) (mm)
900	550	20	25

C25P750

**SMILEY
MONROE**

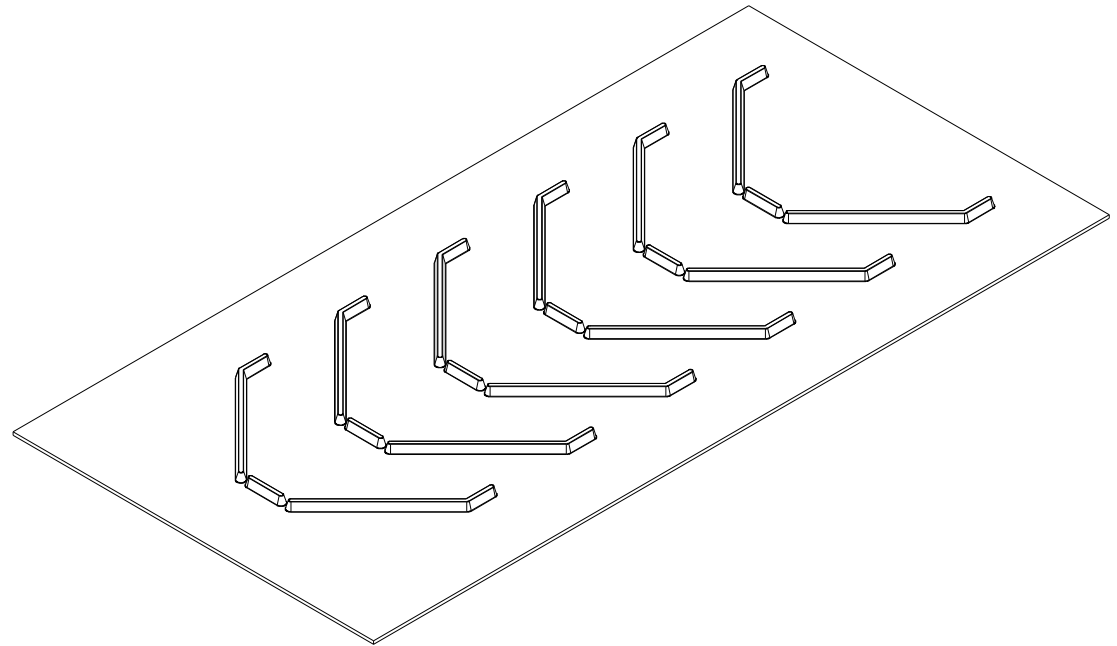
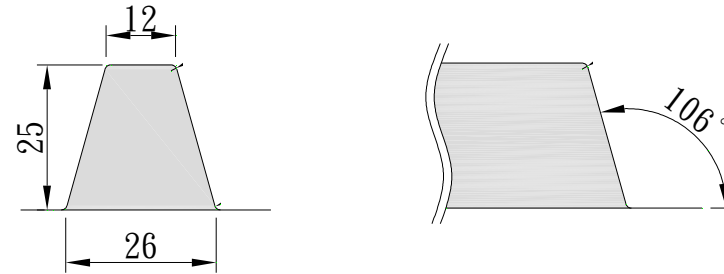
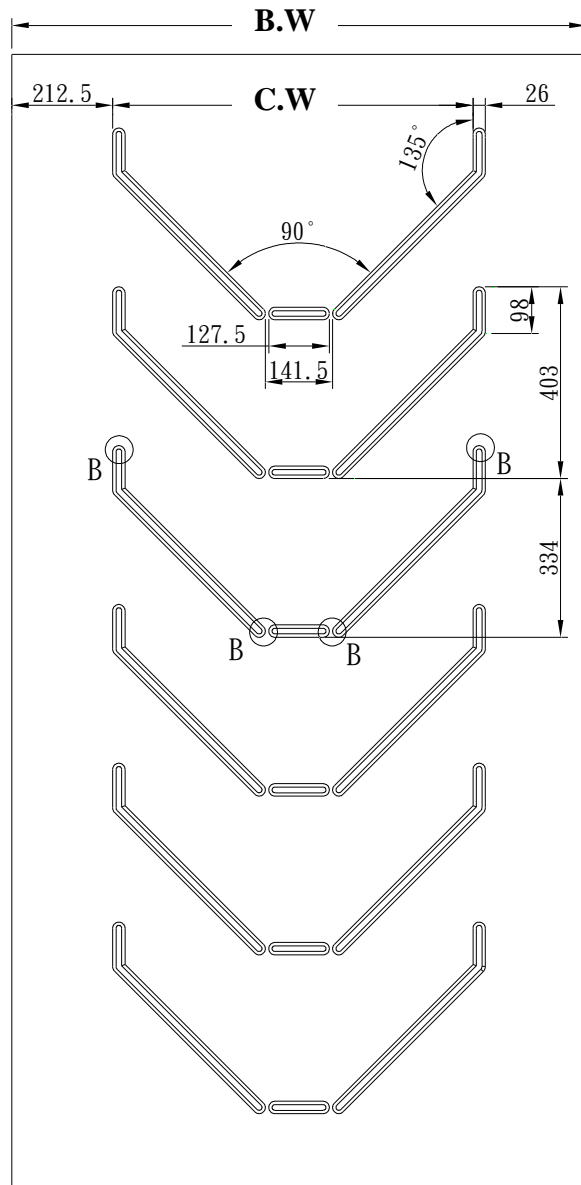

Belt Width (B.W) (mm)	Cleat Width (C.W) (mm)	Cleat Pitch (C.P) (mm)	Cleat Height (C.H) (mm)
1200	785	330	25

S15P750

SMILEY[®]
MONROE

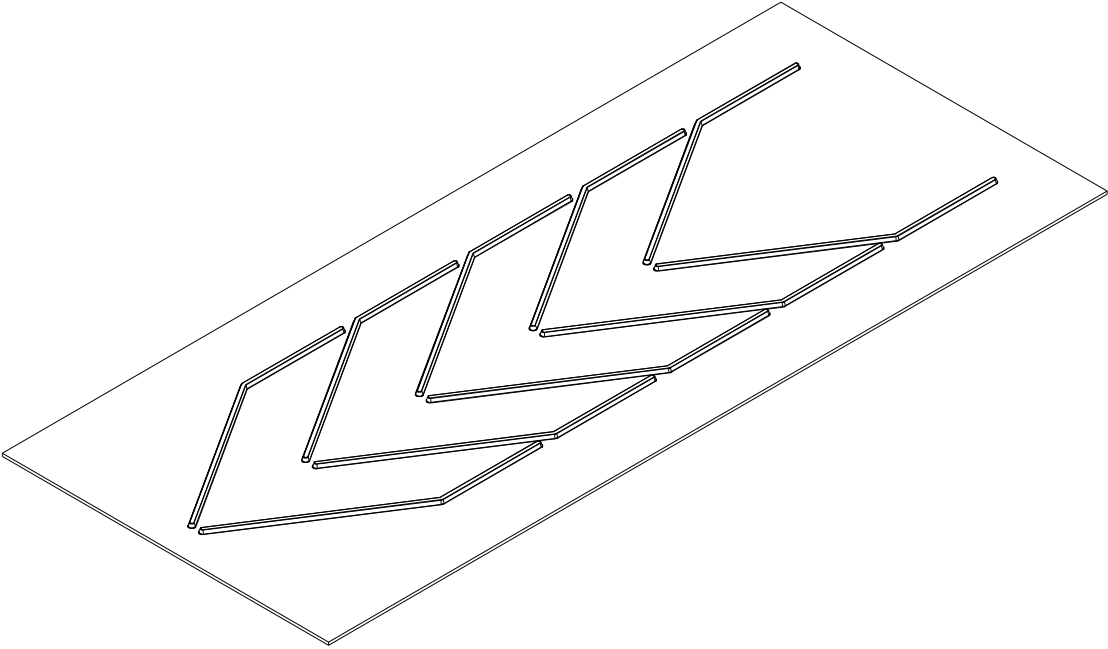
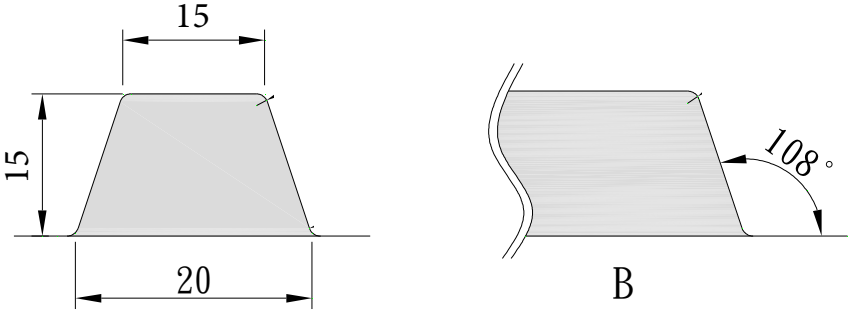
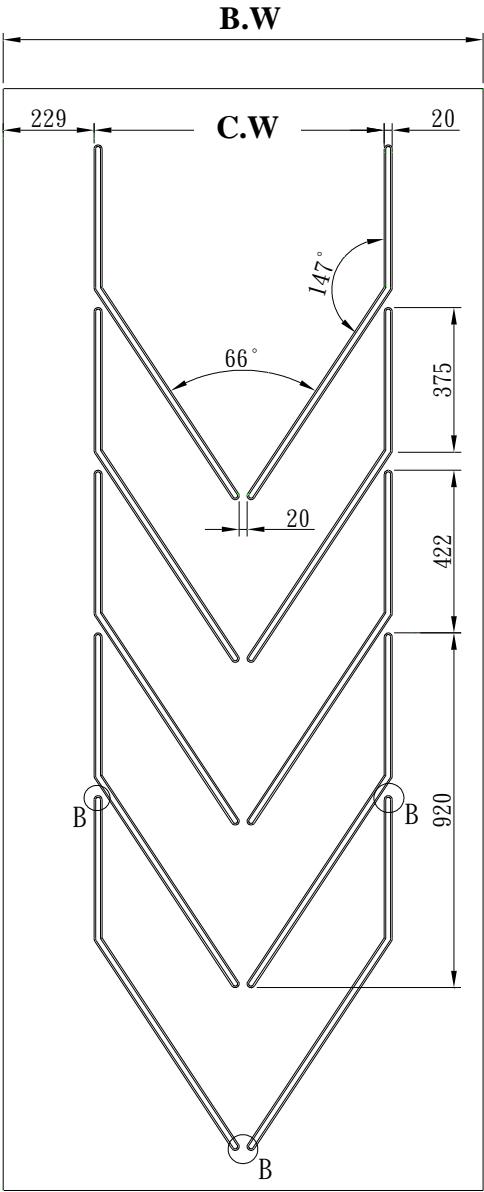

Belt Width (B.W) (mm)	Cleat Width (C.W) (mm)	Cleat Pitch (C.P) (mm)	Cleat Height (C.H) (mm)
1000 & 1200	750	420	15

S25P750

SMILEY[®]
MONROE

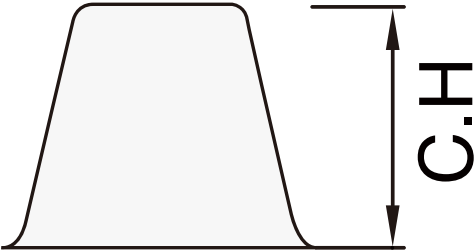
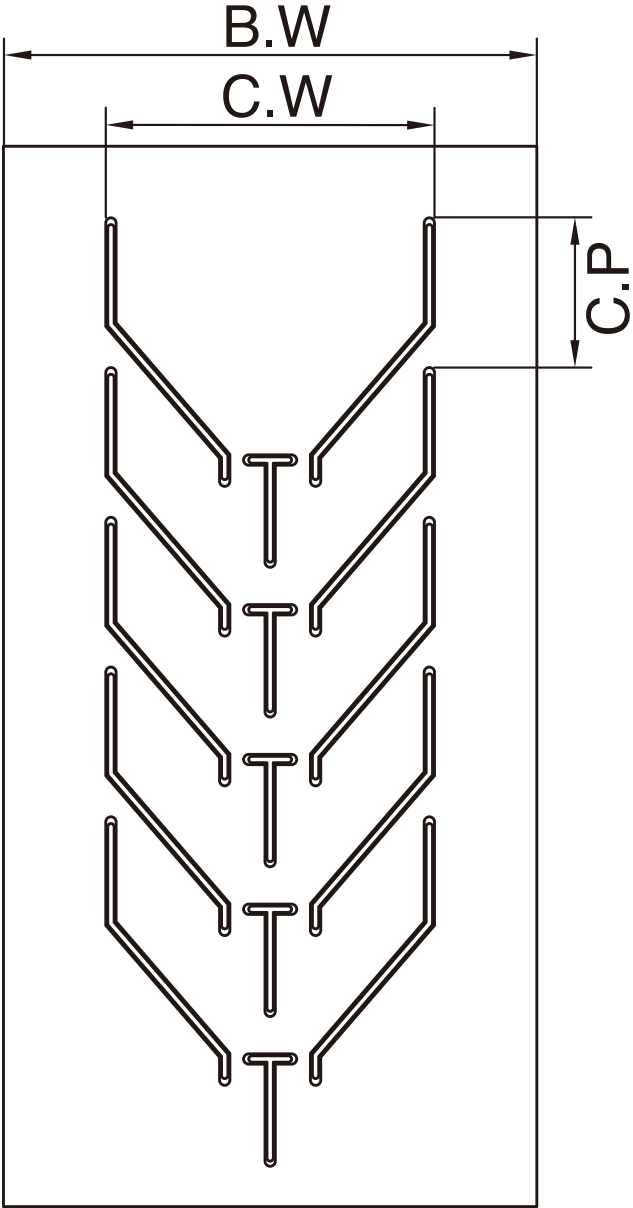

Belt Width (B.W) (mm)	Cleat Width (C.W) (mm)	Cleat Pitch (C.P) (mm)	Cleat Height (C.H) (mm)
1050 & 1200	750	340	25

Y26P400

SMILEY[®]
MONROE

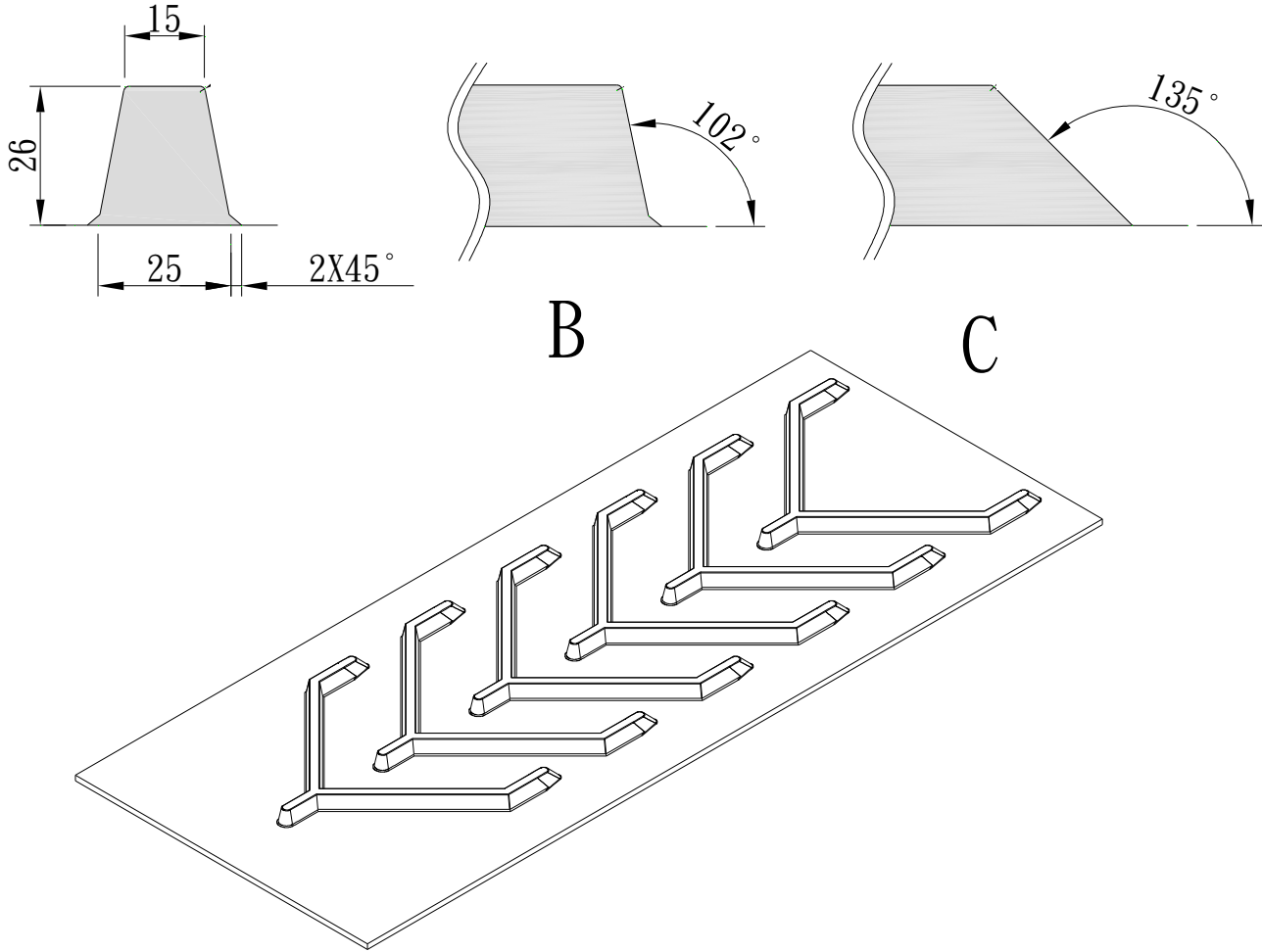
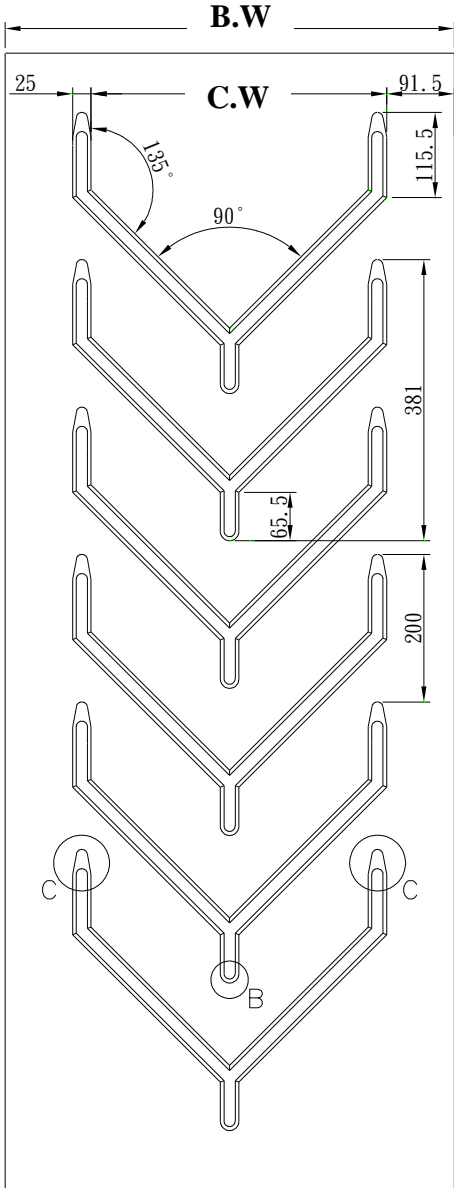

Belt Width (B.W) (mm)	Cleat Width (C.W) (mm)	Cleat Pitch (C.P) (mm)	Cleat Height (C.H) (mm)
500 & 550	425	310	23

Y32P460

**SMILEY[®]
MONROE**

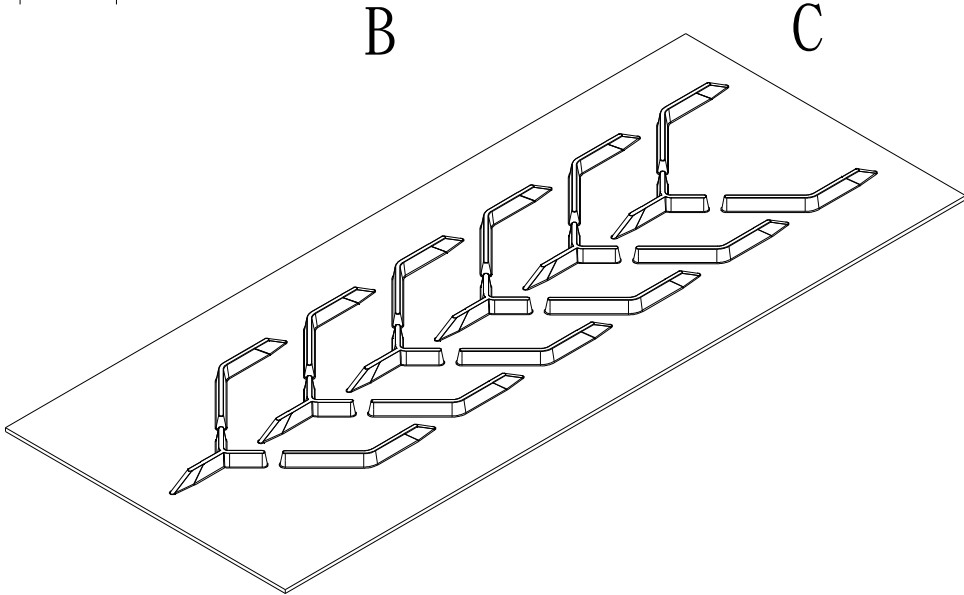
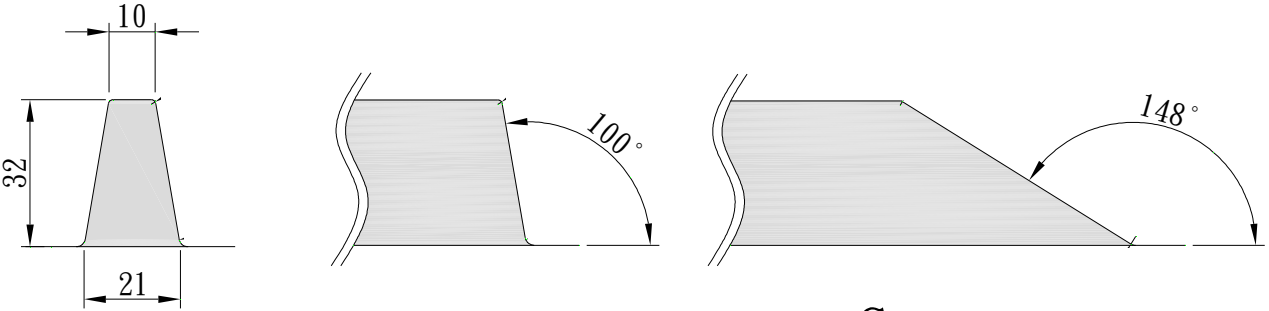
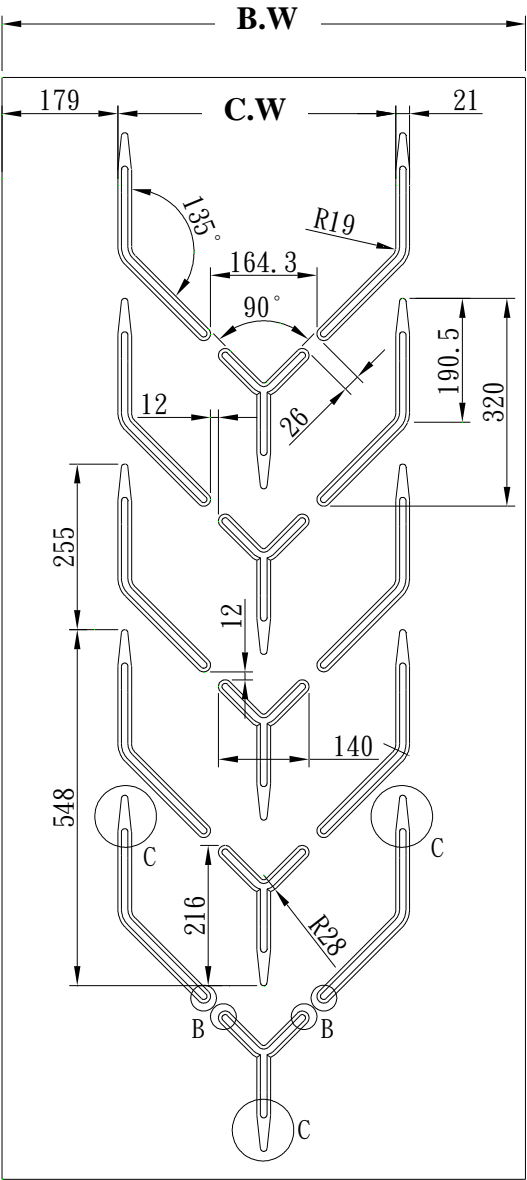

Belt Width (B.W) (mm)	Cleat Width (C.W) (mm)	Cleat Pitch (C.P) (mm)	Cleat Height (C.H) (mm)
650	450	255	32

C25P1000

SMILEY[®]
MONROE

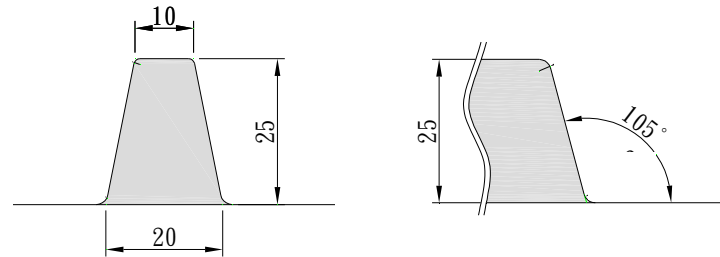
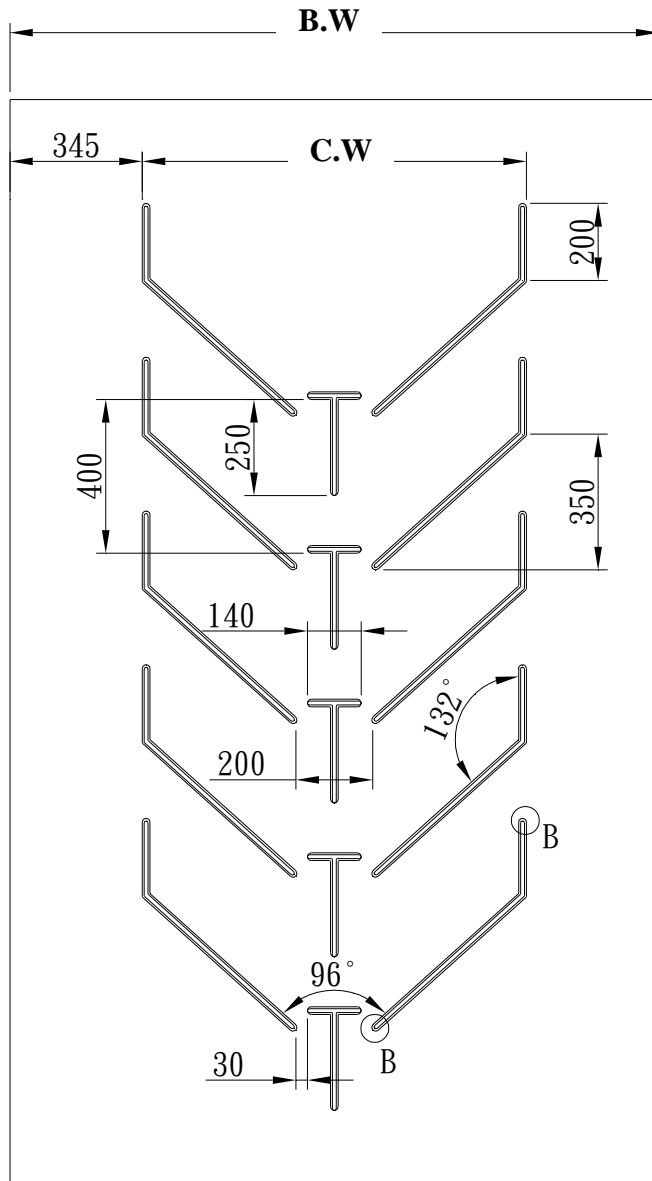

B

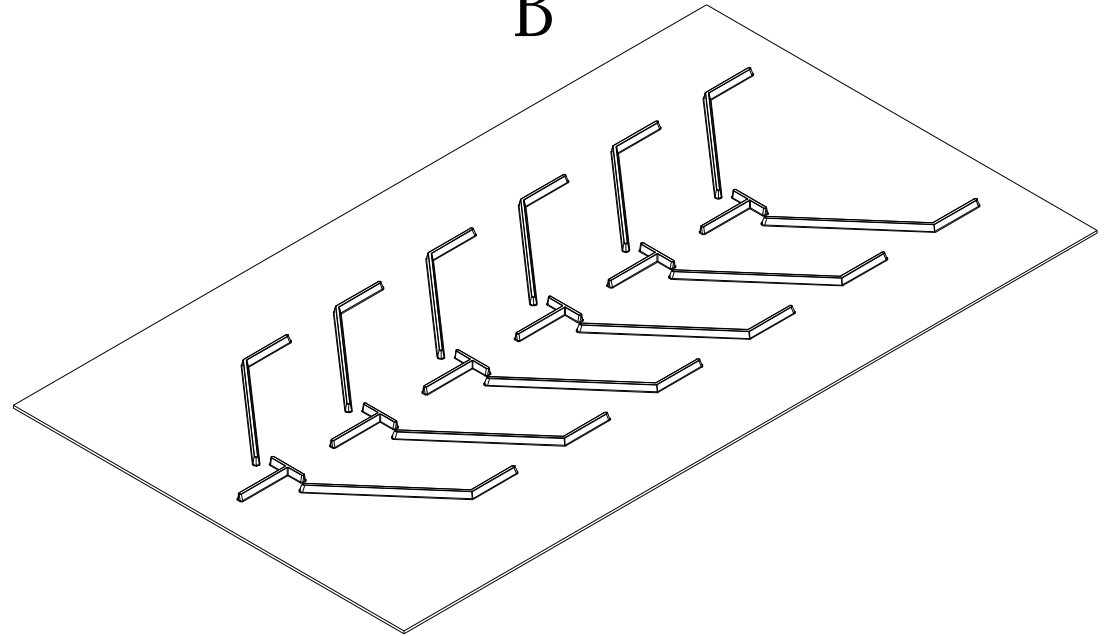

Belt Width (B.W) (mm)	Cleat Width (C.W) (mm)	Cleat Pitch (C.P) (mm)	Cleat Height (C.H) (mm)
1400, 1500 & 1600	1000	400	25

C25P400 SIDE RAIL

SMILEY[®]
MONROE

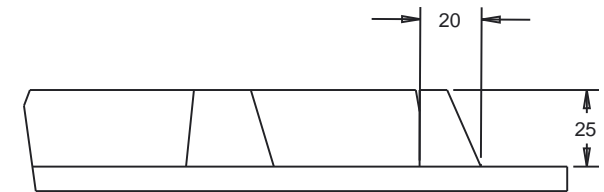
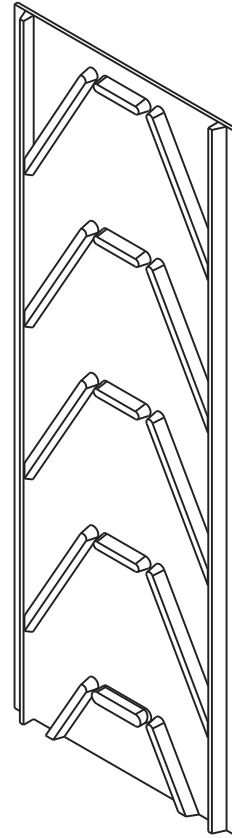
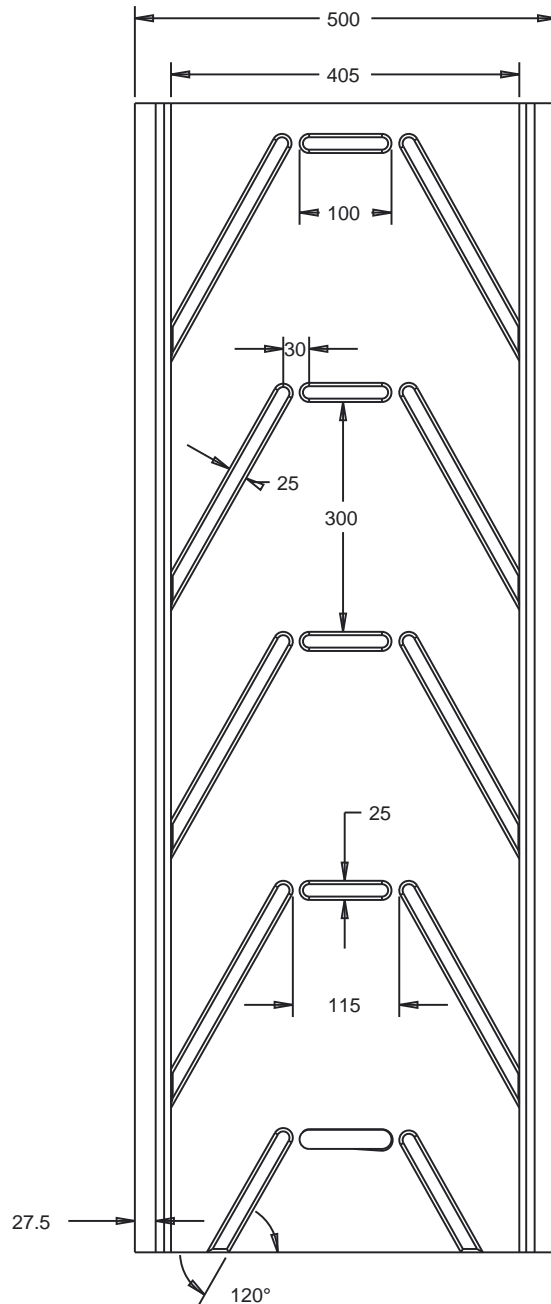

Belt Width (B.W) (mm)	Cleat Width (C.W) (mm)	Cleat Pitch (C.P) (mm)	Cleat Height (C.H) (mm)
500	450	300	25



Head Office & Production Centre

Smiley Monroe Ltd

23 Ferguson Drive
Knockmore Hill Industrial Park
Lisburn
BT28 2EX
Northern Ireland
UNITED KINGDOM

T +44 (0) 28 9267 3777
hello@smileymonroe.com
Smileymonroe.com

Production Centre

Smiley Monroe Inc

205a North Street
Franklin
KY 42134,
USA

T +1 - (270) - 253 - 8001
hello@smileymonroe.com
Smileymonroe.com

Office & Production Centre

**Smiley Monroe Rubber & Allied
Products (India) Pvt Ltd**

14/2C Begapalli Road
Anumpealli]Hosur
Tami Nadu - 635126
INDIA

T +91 (0) 77086 66292
prabhu@smileymonroe.com
Smileymonroe.com

**SMILEY[®]
MONROE**

smileymonroe.com

ISO 9001 OHSAS 18001

